

# **APEX™ High Speed Slot Die**

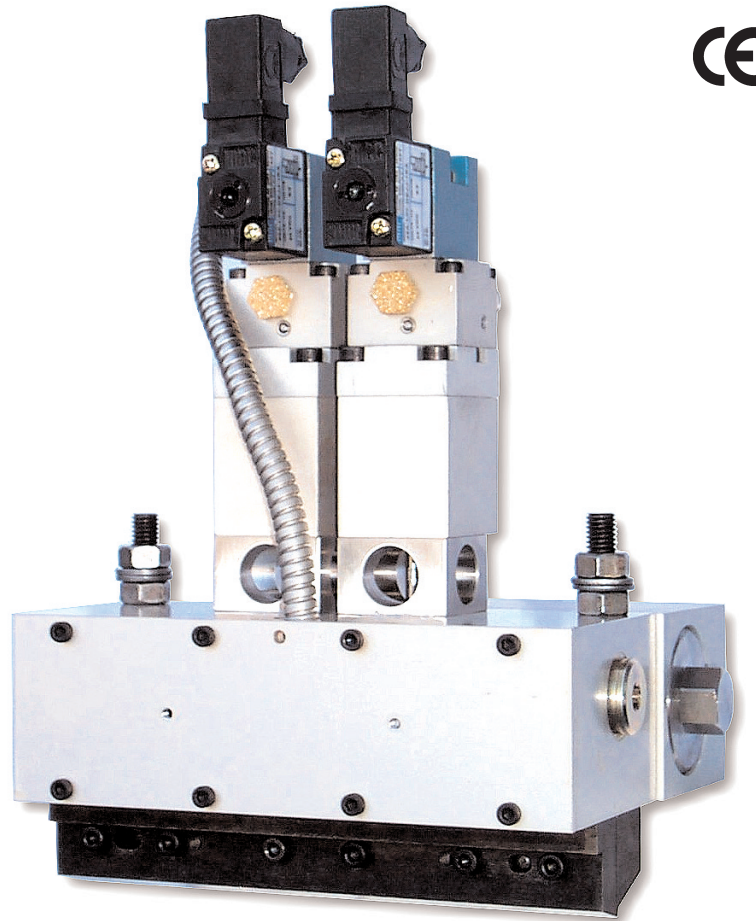

## ***The Dynatec Advantage***

- ***Precise high speed intermittent adhesive patterns.***
- ***Self-cleaning die lips permits the use of a variety of adhesive viscosities.***
- ***Exceptional value for a high speed slot die applicator.***
- ***Slot die design does not require micro adjustments to achieve the required adhesive lay down weights.***
- ***APEX™ SB module with recirculation provides a clean adhesive cutoff regardless of the adhesive pattern.***

# APEX™ High Speed Intermittent Slot Die

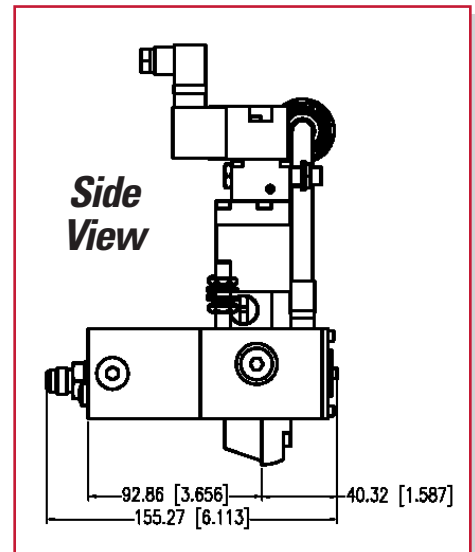
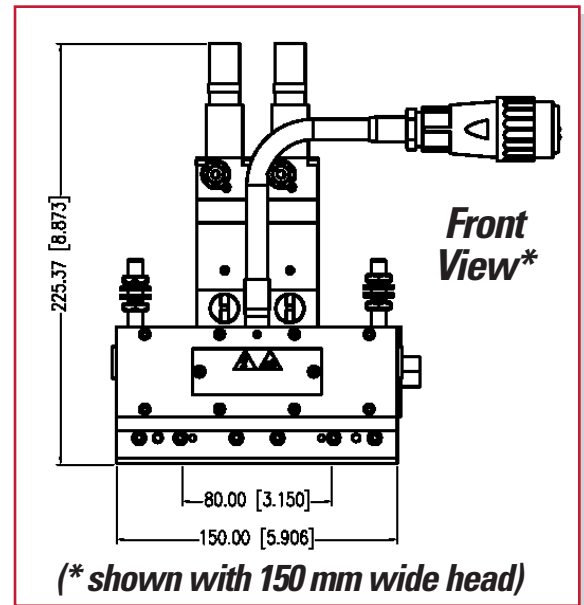
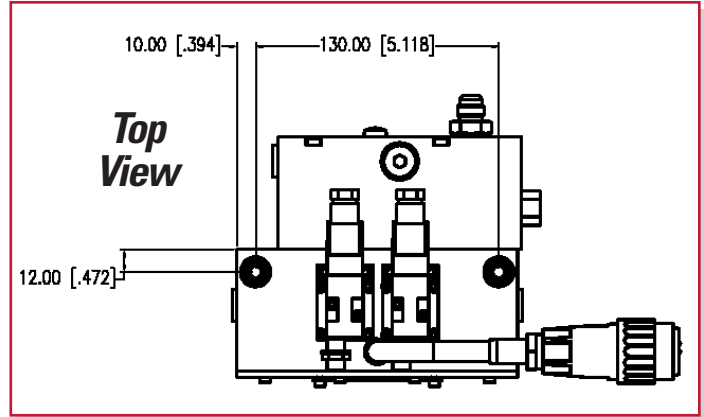
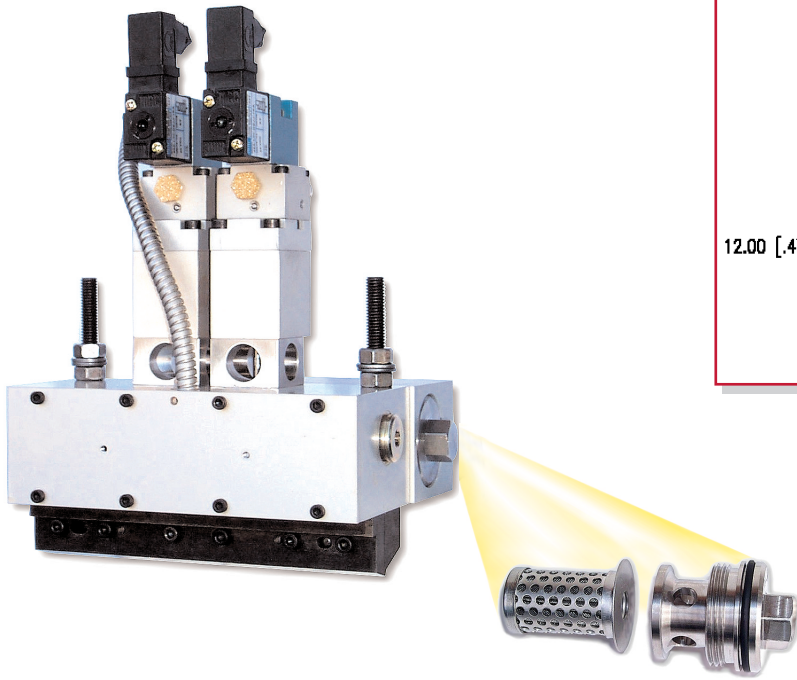

- **Maximum on/off cycle speed 10,000 cycles per minute**
- **Application width up to 500 mm / 19.6 in.**
- **Adhesive viscosity 100 cps min / 20,000 cps max**
- **Maximum operating temperature 200°C / 390°F**
- **Pneumatic pressure 74 psi (5 bar) min / 125 psi (9 bar) max**
- **Adhesive pressure 100 psi (7 bar) min / 1,000 psi (68 bar) max**
- **230 VAC, 50/60 Hz, 1 phase with 24 VDC control voltage**

**ITW Dynatec™**

[itwdynatec.com](http://itwdynatec.com)

Adhesive Application Solutions



**AMERICAS**  
ITW Dynatec  
31 Volunteer Drive  
Hendersonville, TN 37075  
Telephone 615•824•3634  
1•800•860•6150  
Fax 615•264•5248

**ASIA and PACIFIC**  
ITW Dynatec K.K.  
Daiwashinagawa Bldg.,  
7-15, Konan, 3-Chome  
Minato-Ku, Tokyo 108-0075 Japan  
Telephone 81•3•3450•5901  
Fax 81•3•3450•8405

**EUROPE, AFRICA and MIDDLE EAST**  
ITW Dynatec GmbH  
Industriestrasse 28  
D-40822 Mettmann, Germany  
Telephone 49•210•4915•0  
Fax 49•210•491•5111  
e.mail@ITWDynatec.de